

120×120×38 mm

XJHFAN

Bearing Type: Ball/Sleeve bearing

Air Flow: 70~112CFM

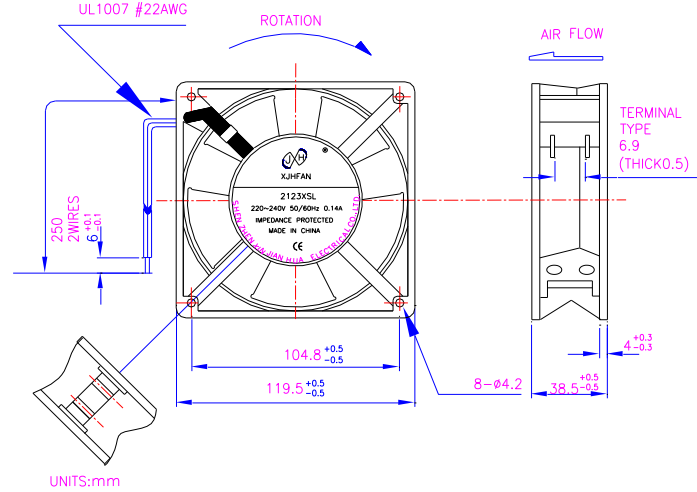
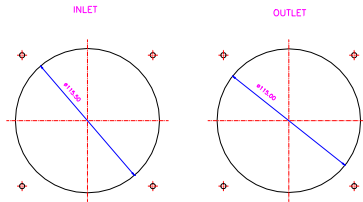

规格型号 P/N	电压 Rating Voltage(VAC)	频率 Frequency (Hz)	电流 Power Current (AMP)	功率 Power Consumption (WATTS)	轴承 Bearing Ball Sleeve	转速 Speed (RPM)	风量 Air Flow (CFM)	风压 Static Pressure (Inch-H ₂ O)	噪声 Noise (dBA)
1123XSL (T)	115	50/60	0.26/0.24	23/22	S	2600/3000	90/110	0.33/0.38	45/49
1123HSL (T)	115	50/60	0.21/0.18	20/18	S	2450/2900	80/100	0.25/0.30	43/48
1123XBL (T)	115	50/60	0.26/0.24	23/22	B	2650/3050	90/112	0.34/0.39	46/50
1123HBL (T)	115	50/60	0.21/0.18	20/18	B	2450/3000	87/107	0.26/0.32	45/50
2123XSL (T)	220/240	50/60	0.14/0.12	23/22	S	2600/3000	95/115	0.33/0.38	44/49
2123HSL (T)	220/240	50/60	0.125/0.11	20/19	S	2450/2900	85/105	0.25/0.30	43/48
2123XBL (T)	220/240	50/60	0.14/0.12	23/22	B	2650/3050	95/117	0.34/0.39	44/49
2123HBL (T)	220/240	50/60	0.125/0.11	20/19	B	2450/2900	87/107	0.26/0.32	43/48
3123XSL	380	50/60	0.06/0.05	12/9	S	2500/2800	80/85	0.25/0.30	44/48
3123XBL	380	50/60	0.06/0.05	12/9	B	2650/2850	80/90	0.28/0.32	45/49

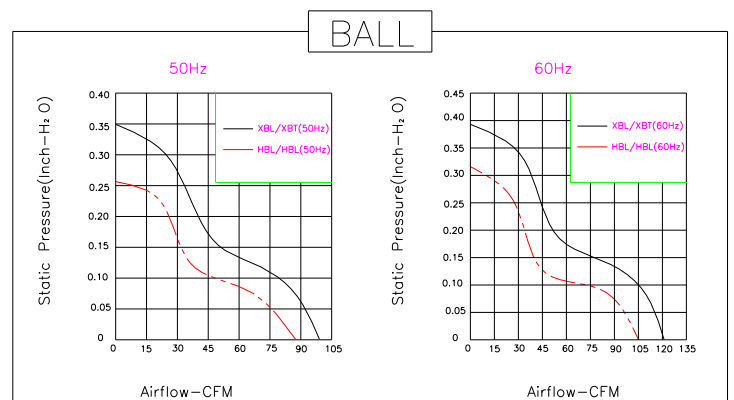
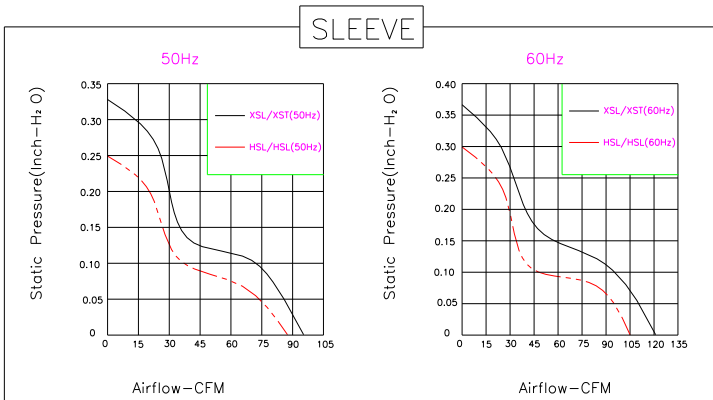

地址：广东省深圳市龙岗区平湖街道世纪工业区 B 区 2 号 3 楼
电话：0755-23735300 13828711071 18948738489
传真：0755-89699793
网址：www.fanon.cn