

120×120×38 mm

XJHFAN

Bearing Type: Ball/Sleeve bearing

Air Flow: 70~112CFM

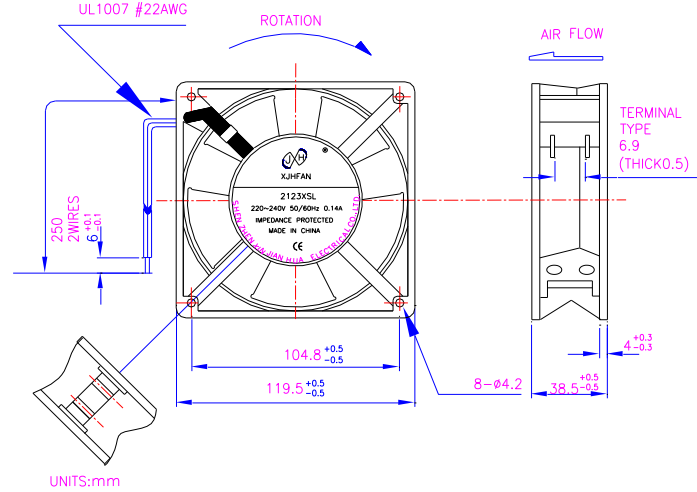
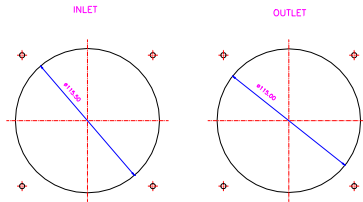

规格型号 P/N	电压 Rating Voltage(VAC)	频率 Frequency (Hz)	电流 Power Current (AMP)	功率 Power Consumption (WATTS)	轴承 Bearing Ball Sleeve	转速 Speed (RPM)	风量 Air Flow (CFM)	风压 Static Pressure (Inch-H ₂ O)	噪声 Noise (dBA)
1123XSL (T)	115	50/60	0.26/0.24	23/22	S	2600/3000	90/110	0.33/0.38	45/49
1123HSL (T)	115	50/60	0.21/0.18	20/18	S	2450/2900	80/100	0.25/0.30	43/48
1123XBL (T)	115	50/60	0.26/0.24	23/22	B	2650/3050	90/112	0.34/0.39	46/50
1123HBL (T)	115	50/60	0.21/0.18	20/18	B	2450/3000	87/107	0.26/0.32	45/50
2123XSL (T)	220/240	50/60	0.14/0.12	23/22	S	2600/3000	95/115	0.33/0.38	44/49
2123HSL (T)	220/240	50/60	0.125/0.11	20/19	S	2450/2900	85/105	0.25/0.30	43/48
2123XBL (T)	220/240	50/60	0.14/0.12	23/22	B	2650/3050	95/117	0.34/0.39	44/49
2123HBL (T)	220/240	50/60	0.125/0.11	20/19	B	2450/2900	87/107	0.26/0.32	43/48
3123XSL	380	50/60	0.06/0.05	12/9	S	2500/2800	80/85	0.25/0.30	44/48
3123XBL	380	50/60	0.06/0.05	12/9	B	2650/2850	80/90	0.28/0.32	45/49

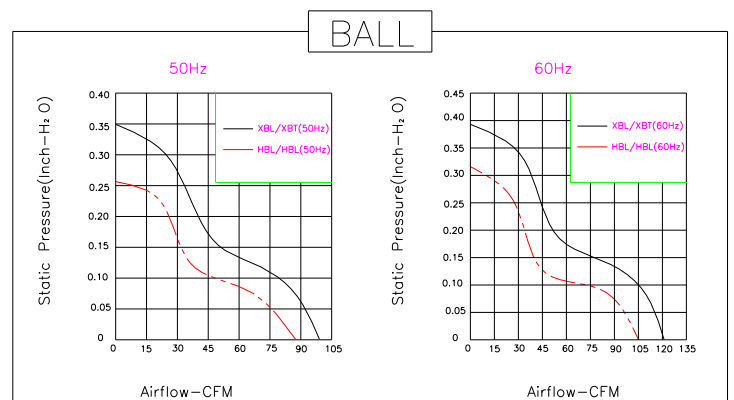
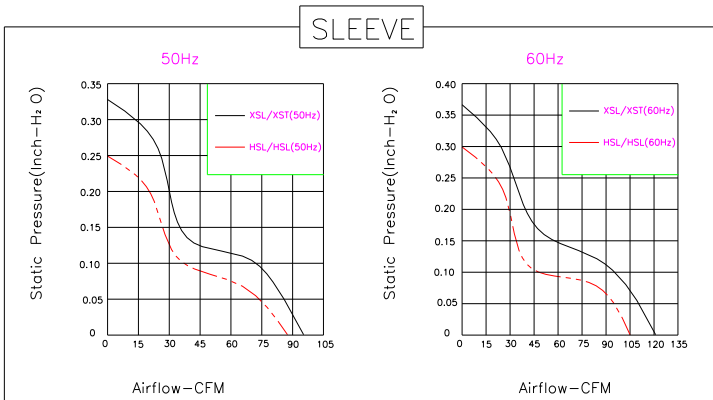

地址：广东省深圳市龙岗区平湖街道世纪工业区 B 区 2 号 3 楼
电话：0755-23735300 13828711071 18948738489
传真：0755-89699793
网址：www.fanon.cn



深圳市鑫晋丰科技有限公司
深圳市鑫建华电机厂

120×120×25 mm

XJHFAN

Bearing Type: Ball/Sleeve bearing

Air Flow: 43~68CFM

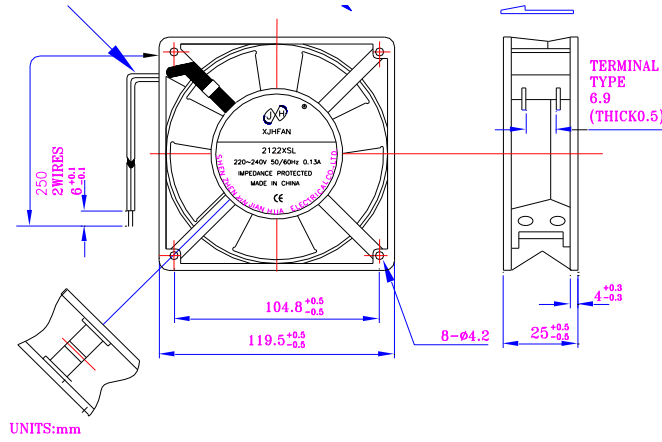
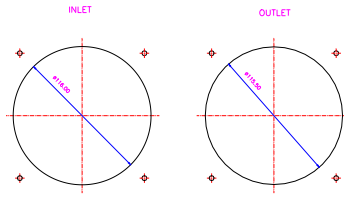

规格型号 P/N	电压 Rating Voltage(VAC)	频率 Frequency (Hz)	电流 Power Current (AMP)	功率 Power Consumption (WATTS)	轴承 Bearing Ball Sleeve	转速 Speed (RPM)	风量 Air Flow (CFM)	风压 Static Pressure (Inch-H ₂ O)	噪声 Noise (dBA)
1122XSL (T)	115	50/60	0.13/0.12	16/14	S	2300/2500	60/65	0.13/0.15	44/46
1122XBL (T)	115	50/60	0.13/0.12	16/14	B	2350/2550	62/68	0.14/0.16	43/48
2122XSL (T)	220/240	50/60	0.13/0.12	16/14	S	2100/2300	60/65	0.13/0.15	43/48
2122XBL (T)	220/240	50/60	0.13/0.12	16/14	B	2150/2350	62/68	0.14/0.15	43/48

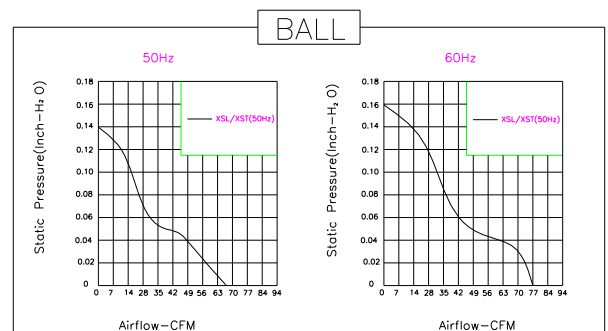
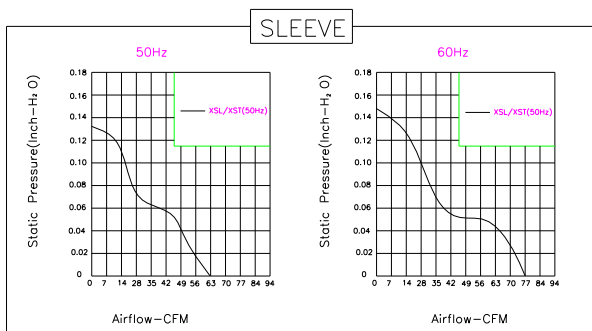

地址：广东省深圳市龙岗区平湖街道世纪工业区 B 区 2 号 3 楼
电话：0755-23735300 13828711071 18948738489
传真：0755-89699793
网址：www.fanon.cn

110×110×25 mm

XJHFAN

Bearing Type: Ball/Sleeve bearing

Air Flow: 43~60CFM

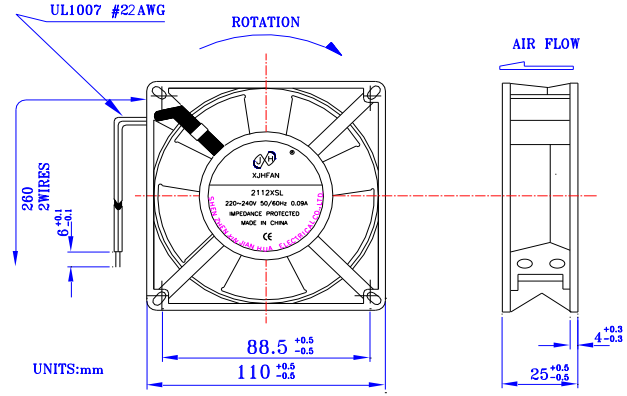
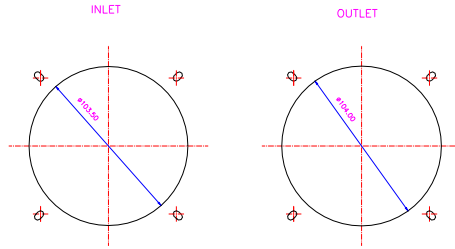

规格型号 P/N	电压 Rating Voltage(VAC)	频率 Frequency (Hz)	电流 Power Current (AMP)	功率 Power Consumption (WATTS)	轴承 Bearing Ball Sleeve	转速 Speed (RPM)	风量 Air Flow (CFM)	风压 Static Pressure (Inch-H ₂ O)	噪声 Noise (dBA)
1112XSL	115	50/60	0.13/0.12	16/14	S	2300/2500	55/60	0.13/0.15	44/46
1112XBL	115	50/60	0.13/0.12	16/14	B	2350/2550	62/68	0.13/0.15	43/48
2112XSL	220/240	50/60	0.09/0.08	18/16	S	2100/2300	60/65	0.13/0.15	43/48
2112XBL	220/240	50/60	0.09/0.08	18/16	B	2150/2350	62/68	0.13/0.15	43/48

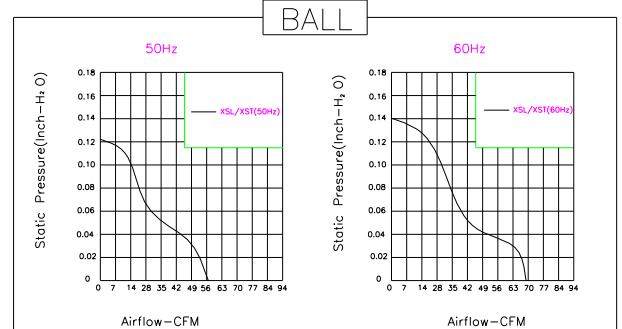
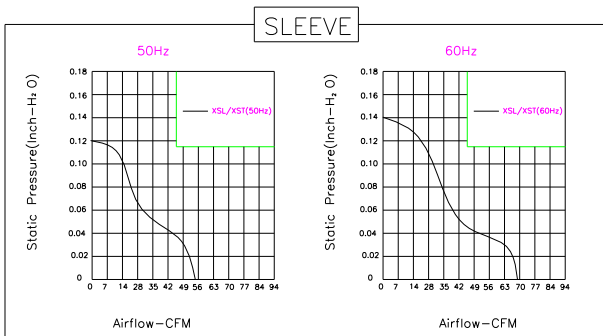

地址：广东省深圳市龙岗区平湖街道世纪工业区 B 区 2 号 3 楼
电话：0755-23735300 13828711071 18948738489
传真：0755-89699793
网址：www.fanon.cn

92×92×25 mm

XJHFAN

Bearing Type: Ball/Sleeve bearing

Air Flow: 43~60CFM

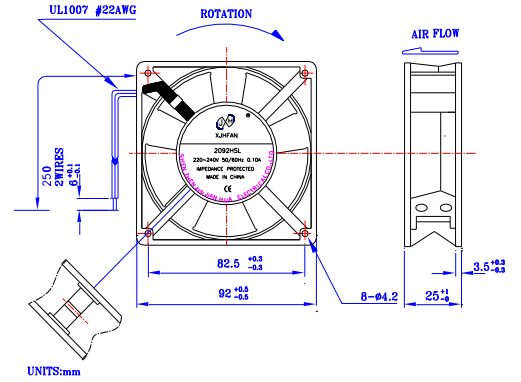
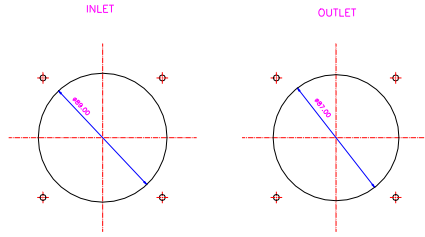

规格型号 P/N	电压 Rating Voltage(VAC)	频率 Frequency (Hz)	电流 Power Current (AMP)	功率 Power Consumption (WATTS)	轴承 Bearing Ball Sleeve	转速 Speed (RPM)	风量 Air Flow (CFM)	风压 Static Pressure (Inch-H ₂ O)	噪声 Noise (dBA)
1092HSL (T)	115	50/60	0.12/0.11	13/12	S	2500/2600	34/36	0.12/0.18	40/42
1092HBL (T)	115	50/60	0.12/0.11	13/12	B	2550/2650	34/36	0.13/0.19	41/43
2092HSL (T)	220/240	50/60	0.10/0.09	16/14	S	2400/2500	27/33	0.12/0.18	40/42
2092HBL (T)	220/240	50/60	0.10/0.09	16/14	B	2550/2650	28/34	0.13/0.19	41/43

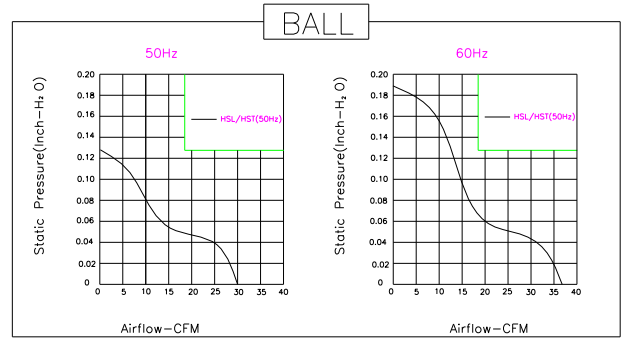
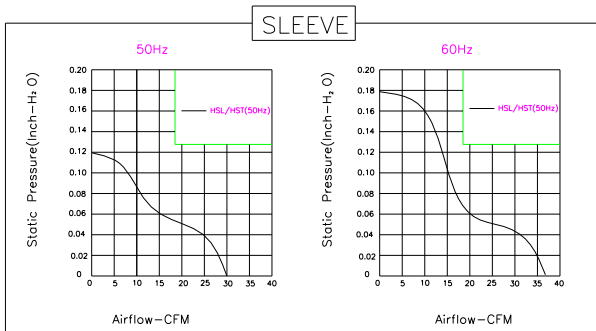

地址：广东省深圳市龙岗区平湖街道世纪工业区 B 区 2 号 3 楼
电话：0755-23735300 13828711071 18948738489
传真：0755-89699793
网址：www.fanon.cn

92×92×38 mm

Bearing Type: Ball/Sleeve bearing

Air Flow: 45CFM



XJHFAN

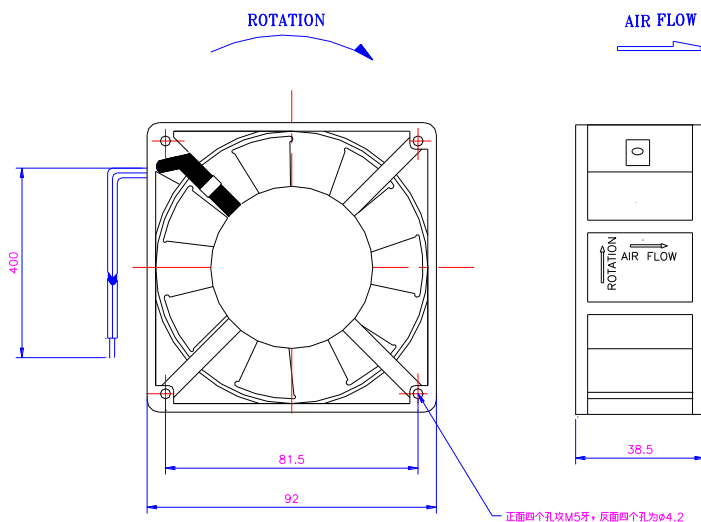

型号 P/N	电压 Rating Voltage(VAC)	频率 Frequency (Hz)	电流 Power Current (AMP)	功率 Power Consumption (WATTS)	轴承 Bearing Ball Sleeve	转速 Speed (RPM)	风量 Air Flow (CFM)	风压 Static Pressure (Inch-H2O)	噪声 Noise (dBA)
1093XBL	115	50/60	0.15/0.18	13	B	2600/3000	42/45	0.12/0.15	35
2093XBL	220/240	50/60	0.09/0.10	15	B	2600/3000	42/45	0.12/0.15	35
1093XSL	115	50/60	0.15/0.18	13	S	2600/3000	42/45	0.12/0.15	35
2093XSL	220/240	50/60	0.09/0.10	15	S	2600/3000	42/45	0.12/0.15	35

地址：广东省深圳市龙岗区平湖街道世纪工业区 B 区 2 号 3 楼

电话：0755-23735300 13828711071 18948738489

传真：0755-89699793

网址：www.fanon.cn

135 × 135 × 38 mm

XJHFAN

Bearing Type: Ball/Sleeve bearing

Air Flow: 70~112CFM

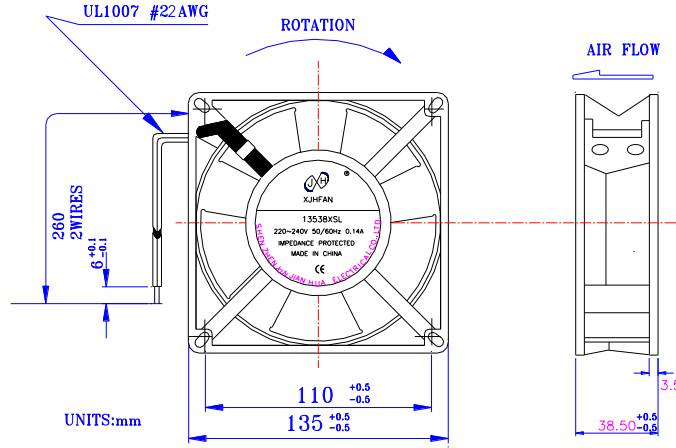

规格型号 P/N	电压 Rating Voltage(VAC)	频率 Frequency (Hz)	电流 Power Current (AMP)	功率 Power Consumption (WATTS)	轴承 Bearing Ball Sleeve	转速 Speed (RPM)	风量 Air Flow (CFM)	风压 Static Pressure (Inch-H ₂ O)	噪声 Noise (dBA)
13538XSL (T)	115	50/60	0.26/0.24	23/22	S	2500/2850	90/110	0.33/0.38	45/49
13538XBL (T)	115	50/60	0.26/0.24	23/22	B	2550/2850	90/112	0.34/0.39	46/50
13538XSL (T)	220/240	50/60	0.14/0.12	23/22	S	2500/2850	95/115	0.33/0.38	44/49
13538XBL (T)	220/240	50/60	0.14/0.12	23/22	B	2550/2850	95/117	0.34/0.39	44/49
13538XSL (T)	380	50/60	0.06/0.05	12/9	S	2500/2850	80/85	0.25/0.30	44/48
13538XBL (T)	380	50/60	0.06/0.05	12/9	B	2650/2850	80/90	0.28/0.32	45/49

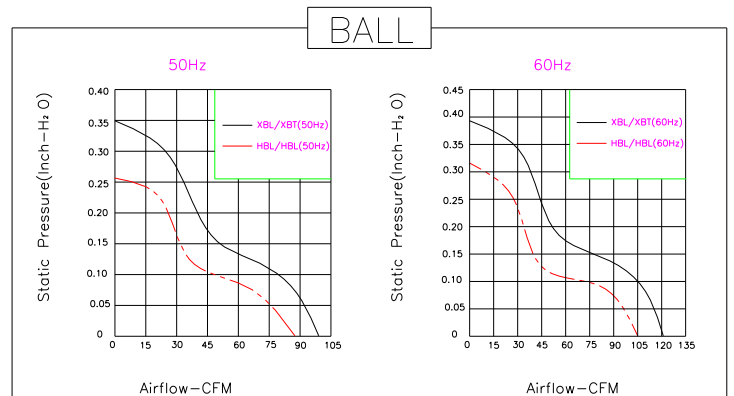
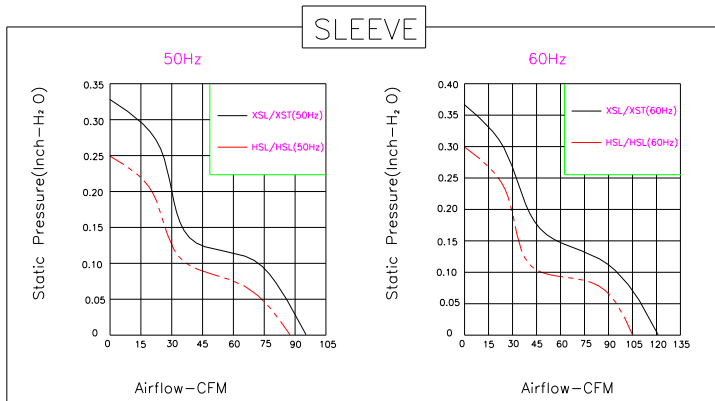

地址：广东省深圳市龙岗区平湖街道世纪工业区 B 区 2 号 3 楼
电话：0755-23735300 13828711071 18948738489
传真：0755-89699793
网址：www.fanon.cn

80×80×38 mm

XJHFAN

Bearing Type: Ball/Sleeve bearing

Air Flow: 23~31CFM

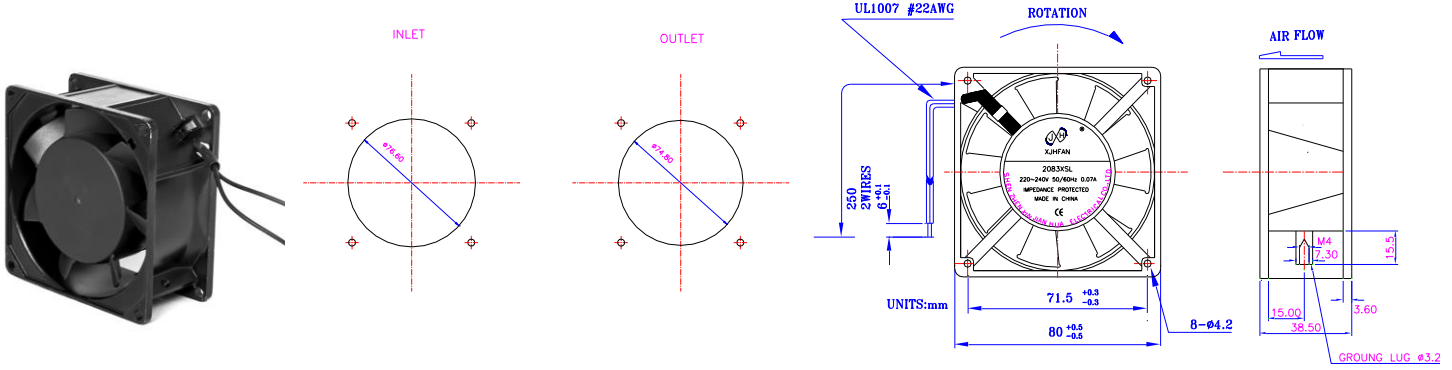

规格型号 P/N	电压 Rating Voltage(VAC)	频率 Frequency (Hz)	电流 Power Current (AMP)	功率 Power Consumption (WATTS)	轴承 Bearing Ball Sleeve	转速 Speed (RPM)	风量 Air Flow (CFM)	风压 Static Pressure (Inch-H ₂ O)	噪声 Noise (dBA)
1083HSL	115	50/60	0.12/0.11	11/10	S	2300/2600	23/30	0.12/0.18	31/35
1083HBL	115	50/60	0.12/0.11	11/10	B	2400/2650	24/31	0.13/0.19	32/36
2083HSL	220/240	50/60	0.07/0.06	13/12	S	2300/2600	23/29	0.12/0.18	31/35
2083HBL	220/240	50/60	0.07/0.06	13/12	B	2400/2650	24/31	0.13/0.19	32/36

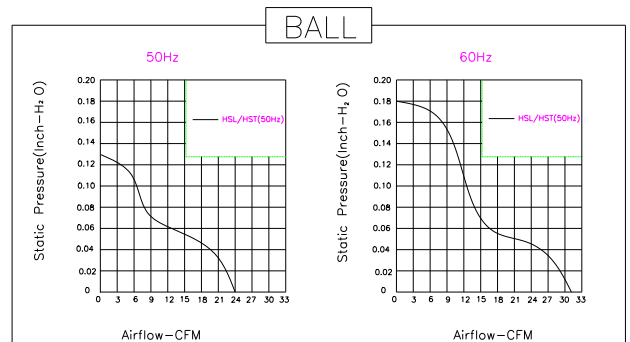
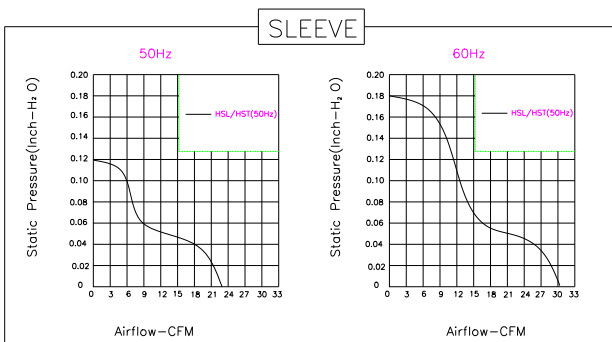

地址：广东省深圳市龙岗区平湖街道世纪工业区 B 区 2 号 3 楼
 电话：0755-23735300 13828711071 18948738489
 传真：0755-89699793
 网址：www.fanon.cn

80×80×25 mm

XJHFAN

Bearing Type: Ball/Sleeve bearing

Air Flow: 17~22CFM

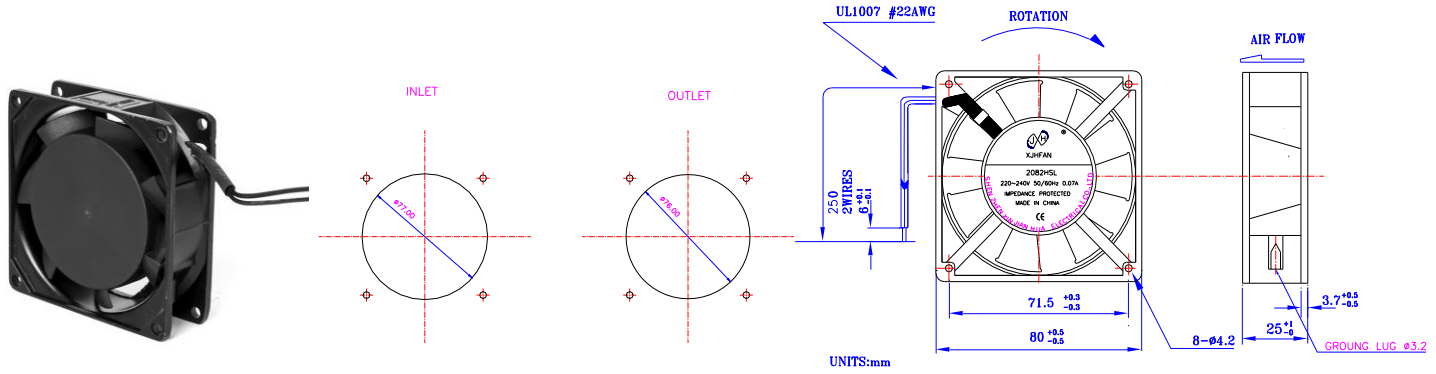

规格型号 P/N	电压 Rating Voltage(VAC)	频率 Frequency (Hz)	电流 Power Current (AMP)	功率 Power Consumption (WATTS)	轴承 Bearing Ball Sleeve	转速 Speed (RPM)	风量 Air Flow (CFM)	风压 Static Pressure (Inch-H ₂ O)	噪声 Noise (dBA)
1082HSL	115	50/60	0.12/0.10	12/11	S	2300/2750	17/21	0.12/0.18	31/35
1082HBL	115	50/60	0.15/0.13	12/11	B	2450/2900	18/22	0.13/0.19	32/36
2082HSL	220/240	50/60	0.07/0.06	14/13	S	2300/2750	17/21	0.12/0.18	31/35
2082HBL	220/240	50/60	0.07/0.06	14/13	B	2450/2900	18/22	0.13/0.19	32/36

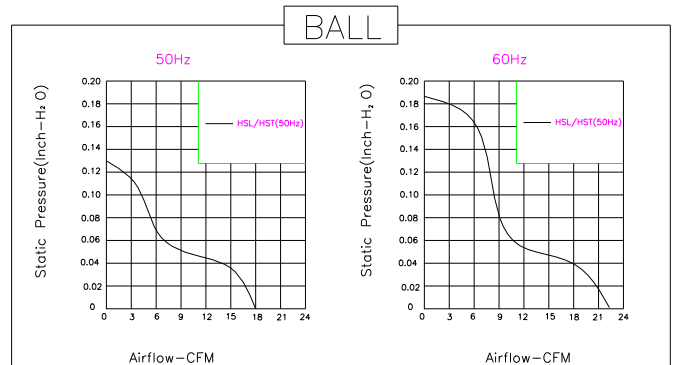
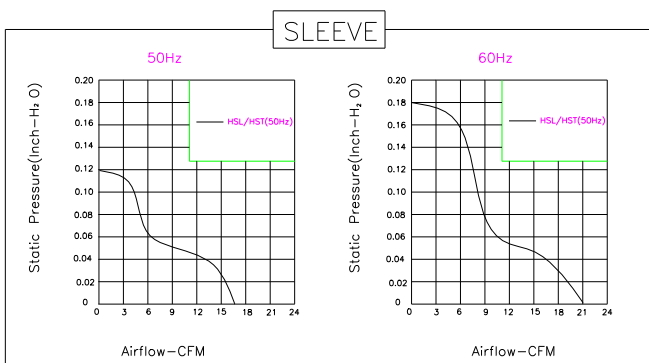

地址：广东省深圳市龙岗区平湖街道世纪工业区 B 区 2 号 3 楼
电话：0755-23735300 13828711071 18948738489
传真：0755-89699793
网址：www.fanon.cn

172×151×51 mm

Bearing Type: Ball/Sleeve bearing

Air Flow: 145~180CFM

XJHFAN

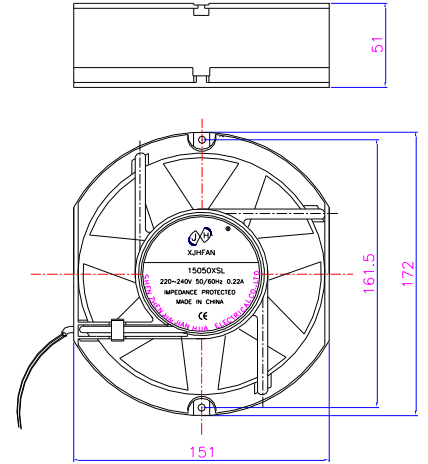
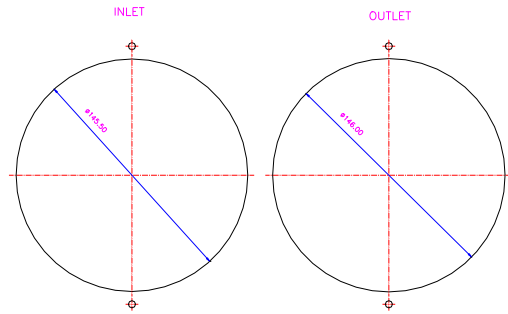

规格型号 P/N	电压 Rating Voltage(VAC)	频率 Frequency (Hz)	电流 Power Current (AMP)	功率 Power Consumption (WATTS)	轴承 Bearing Ball Sleeve	转速 Speed (RPM)	风量 Air Flow (CFM)	风压 Static Pressure (Inch-H ₂ O)	噪声 Noise (dBA)
15050XBL (T)	115	50/60	0.40./0.45	49/45	B	2650/2950	150/180	0.38/0.48	55/60
15050XSL (T)	115	50/60	0.40/0.45	49/45	S	2600/2700	145/170	0.35/0.45	53/58
15050XBL (T)	220/240	50/60	0.22./0.21	37/35	B	2600/2800	145/160	0.33/0.43	52/57
15050XSL (T)	220/240	50/60	0.22/0.21	37/35	S	2600/2700	145/170	0.35/0.45	53/58
15050XBL (T)	380	50	0.15	40	B	2600	145	0.35	55
15050XSL (T)	380	50	0.15	40	S	2550	140	0.33	52

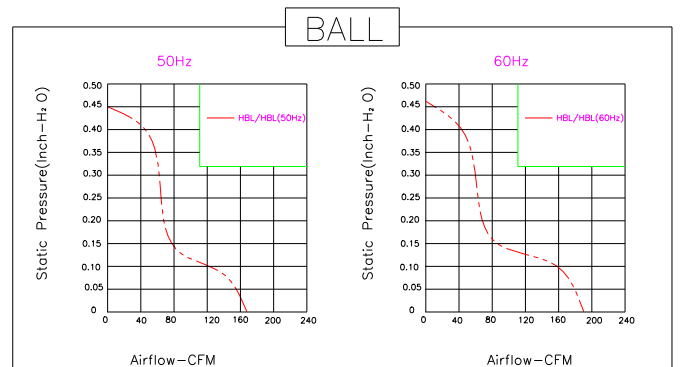
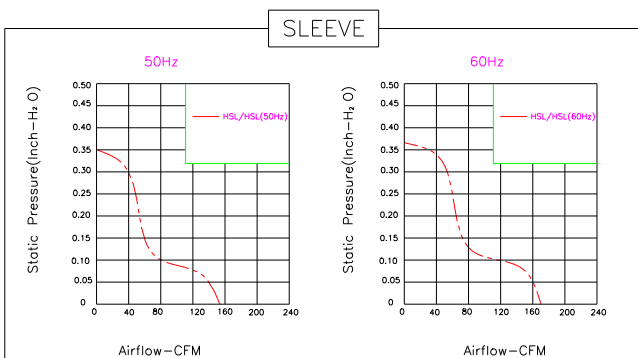

地址：广东省深圳市龙岗区平湖街道世纪工业区 B

电话：0755-23735300 13828711071 18948738489

传真：0755-89699793

网址：www.fanon.cn

150×150×50 mm

XJHFAN

Bearing Type: Ball/Sleeve bearing

Air Flow: 180CFM

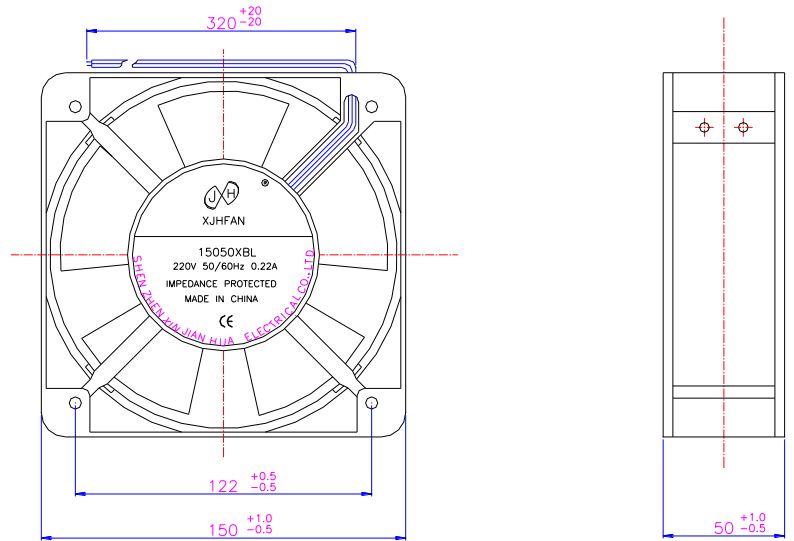

规格型号 P/N	电压 Rating Voltage(VAC)	频率 Frequency (Hz)	电流 Power Current (AMP)	功率 Power Consumption (WATTS)	轴承 Bearing Ball Sleeve	转速 Speed (RPM)	风量 Air Flow (CFM)	风压 Static Pressure (Inch-H ₂ O)	噪声 Noise (dBA)
15050XBL (T)	115	50/60	0.40./0.45	49/45	B	2650/2950	150/180	0.38/0.48	55/60
15050XSL (T)	115	50/60	0.40/0.45	49/45	S	2600/2700	145/170	0.35/0.45	53/58
15050XBL (T)	220/240	50/60	0.22./0.21	37/35	B	2600/2800	145/160	0.33/0.43	52/57
15050XSL (T)	220/240	50/60	0.22/0.21	37/35	S	2600/2700	145/170	0.35/0.45	53/58
15050XBL (T)	380	50	0.15	40	B	2600	145	0.35	55
15050XSL (T)	380	50	0.15	40	S	2550	140	0.33	52

地址：广东省深圳市龙岗区平湖街道世纪工业区 B 区 2 号 3 楼

电话：0755-23735300 13828711071 18948738489

传真：0755-89699793

网址：www.fanon.cn

172×151×51 mm (17251-C)

Bearing Type: Ball/Sleeve bearing

Air Flow: 145~180CFM

XJHFAN

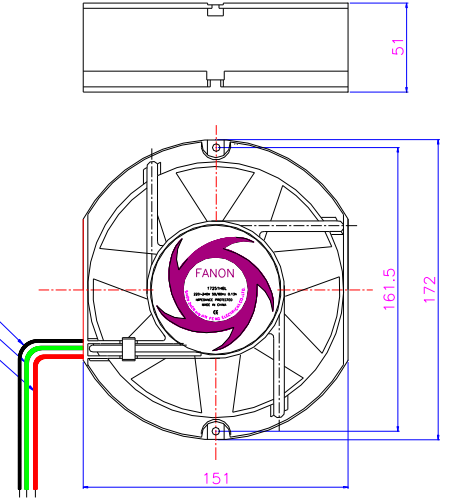
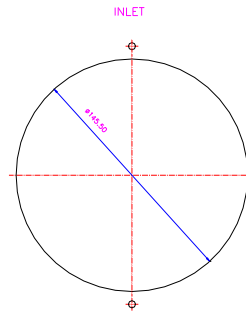

编号 Model	型号 P/N	电压 Rating Voltage(VAC)	频率 Frequency (Hz)	电流 Power Current (AMP)	功率 Power Consumption (WATTS)	轴承 Bearing Ball Sleeve	转速 Speed (RPM)	风量 Air Flow (CFM)	风压 Static Pressure (Inch-H2O)	噪声 Noise (dBA)
A1175HBL-C	JZ15050HBL(T)	115	50/60	0.40/.0.45	49/45	B	2650/2950	150/180	0.38/0.48	55/60
A1175HSL-C	JZ15050HSL(T)	115	50/60	0.40/0.45	49/45	S	2600/2700	145/170	0.35/0.45	53/58
A2175HBL-C	JZ15050HBL(T)	220/240	50/60	0.13/.0.12	28/26	B	2600/2800	145/160	0.33/0.43	52/57
A2175HSL-C	JZ15050HSL(T)	220/240	50/60	0.13/0.12	28/26	S	2600/2700	145/170	0.35/0.45	53/58

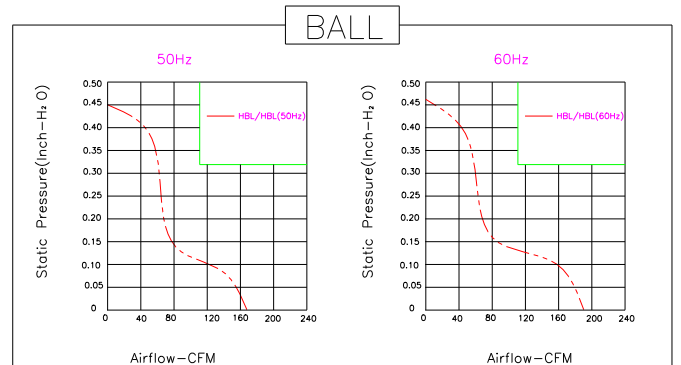
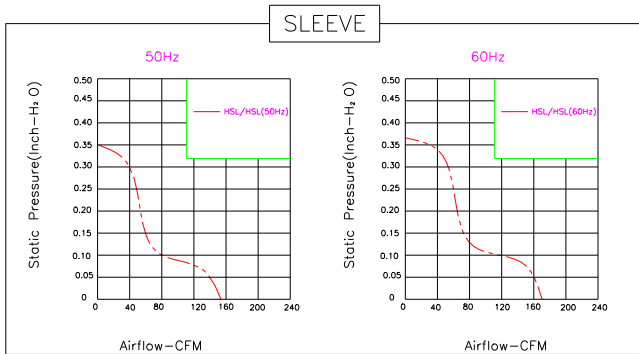

地址：广东省深圳市龙岗区平湖街道世纪工业区B区2号3楼
电话：0755-23735300 13828711071 18948738489
传真：0755-89699793
网址：www.fanon.cn

200 × 200 × 60 mm

XJHFAN

Bearing Type: Ball/Sleeve bearing

Air Flow: 350CFM

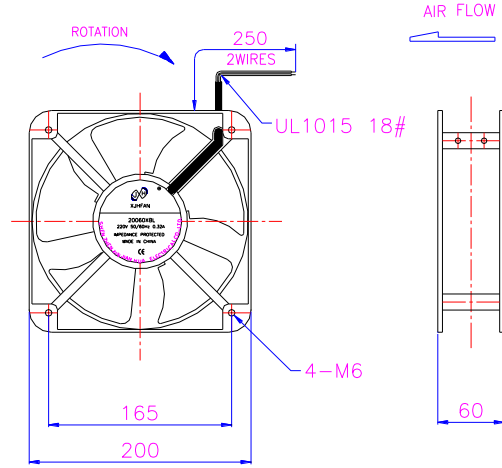

型号 P/N	电压 Rating Voltage(VAC)	频率 Frequency (Hz)	电流 Power Current (AMP)	功率 Power Consumption (WATTS)	轴承 Bearing Ball Sleeve	转速 Speed (RPM)	风量 Air Flow (CFM)	风压 Static Pressure (Inch-H2O)	噪声 Noise (dBA)
JZ20060HBL	115	50/60	0.60/0.55	58/55	B	2600/2800	340/350	0.38/0.48	58
JZ20060HBL	220/240	50/60	0.36/0.32	55/52	B	2600/2800	330/350	0.33/0.43	58

地址：广东省深圳市龙岗区平湖街道世纪工业区 B 区 2 号 3 楼
电话：0755-23735300 13828711071 18948738489
传真：0755-89699793
网址：www.fanon.cn